



**MAKER WEB**

**CNC BASICS**

**CNC BASICS**

# **PART 1** CNC BASICS: DEFINITION AND HISTORY

CNC = Computer Numerical Control. A computer "controller" reads G-code or machine language instructions and drives a tool. The NC (Numerical control) file is a detailed set of step by step instructions that tell the machine which path to follow and which operations to perform. This is generally created in RhinoCAM which is a plug-in for Rhino. It is available in the computer lab. In general CNC technology is not very complicated. It is a tool controlled by a computer. It only becomes more sophisticated when considering how the computer controls the tool. The illustration below shows what a bare bones CNC machine might look like minus the controller..

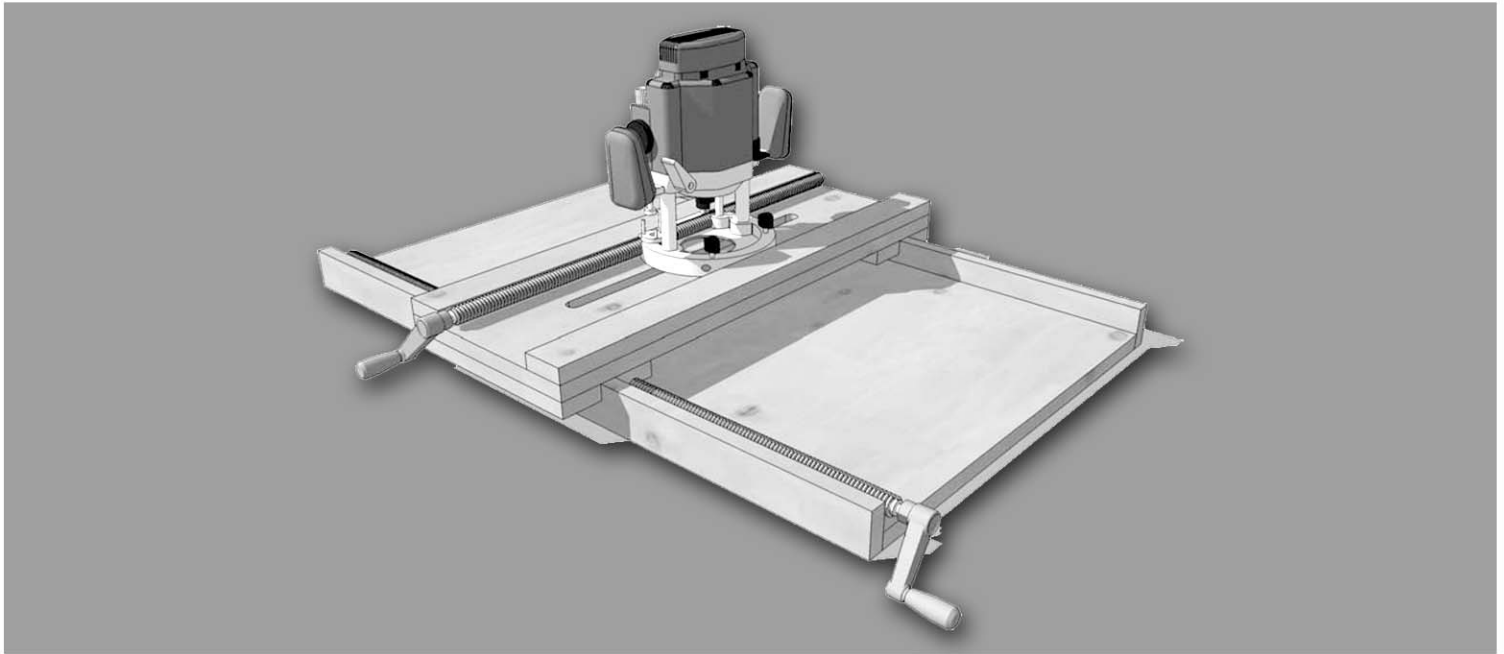

NC or simply Numerical Control was developed in the late 1940s and early 1950s by John T. Parsons in collaboration with MIT (Massachusetts Institute of Technology). It was developed to help in the post war manufacturing effort. Aircraft parts were becoming more complex and required a level of precision that human operators could not achieve.

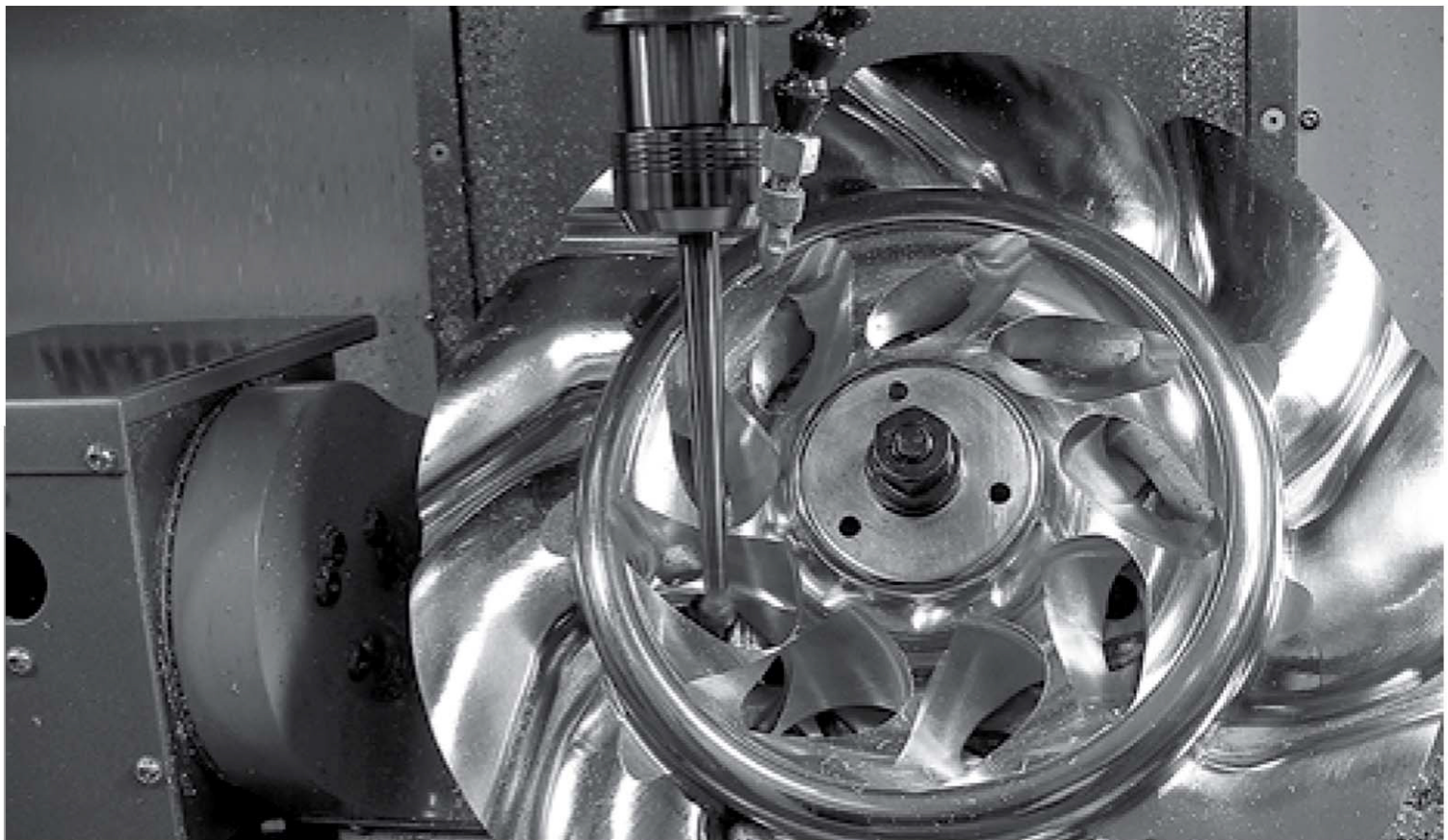

# **PART 1** CNC BASICS: 3 AND 5 AXIS and SHOP MACHINES

3-axis machines move in a Cartesian manner along x, y and z. A fourth axis often takes the form of a rotating device for the part being cut, similar to a lathe or an indexing head along the spindle that permits the controlled rotation of an aggregate tool. 5-axis machines have a much greater range of motion and can move in a manner similar to the human hand. There are 6 possible axes of motion, 3 linear and 3 rotational, one of which is considered to be the cutter spinning in the spindle.

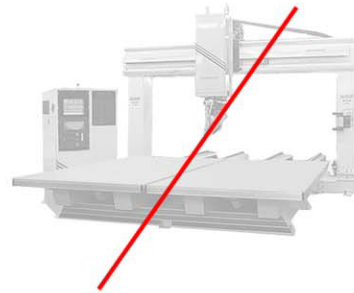
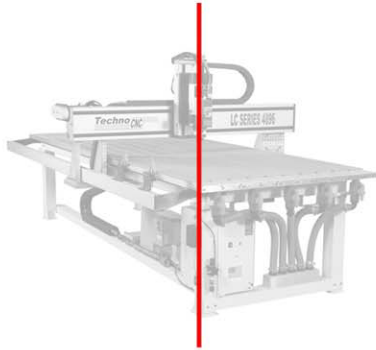

The CNC Lab is located in Feigenbaum Center for Visual Arts in the Metal Shop. We currently have one Laguna Swift 4' x 8' 3 axis machine. The machine has a vacuum bed to hold down material and has an effective cutting area of 48" x 96" x 8".



# PART 1 CNC BASICS: BASIC MILLING OPERATIONS

## BASIC MILLING OPERATIONS AND CUT TYPES

PROFILING (cutting out shapes or pieces to be assembled)



SURFACING (cutting 3D geometries or textures)



BIT BASED TEXTURES (cutting lines or 3D geometries but using different bits to yield varying and unexpected results)

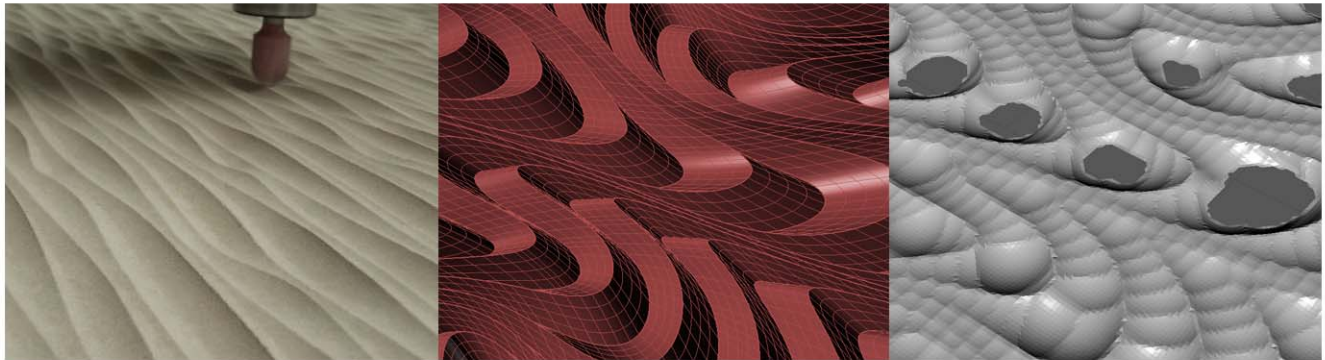

HYBRIDS (there are many milling techniques and assembly methods that will yield radically different results.)



## CNC CHIPLOAD CHART

Chip load refers to the size of the chip of material cut by each cutting flute each time it passes through the material. Cutting with the appropriate chipload will result in the smoothest finish, and will help prolong tool life.

Chip load is based on the number of flutes the tool has, the spindle speed, and the feed rate. Performing a chip load calculation will help you to determine a target feedrate.

Chipload is less important for blue foam or high-density foam. It becomes more important for harder materials like MDF and plywood, and especially metals.

Additional chip load charts are available in the Onsrud PDF catalog, available at [www.onsrud.com](http://www.onsrud.com) for all Onsrud tools and a wider variety of materials.

These chip loads assume the cut depth is 1 x diameter of the tool. For deeper cuts, follow these guidelines:

$$2xD = .75 \times \text{chip load}$$

$$3xD = .50 \times \text{chip load}$$

For the XYZ router in denser materials, start with 200 ipm as the feedrate and adjust up or down so that spindle speed is in the 8,000-16,000 RPM range. Appropriate feedrates and spindle speeds vary by machine.

For blue foam, use 500 ipm as the feedrate for roughing passes, and 200 ipm or lower for finish passes with a spindle speed of 18,000 RPM.

Tool Number		Material				
		Soft Wood	Hard Wood	MDF	Plywood	Blue Foam
52-244	1/8" flat endmill	.006-.008	.003-.005	.005-.007	.003-.005	100 ipm/18k
52-244B	1/8" ball endmill	.006-.008	.003-.005	.005-.007	.003-.005	100 ipm/18k
52-360B	3/16" ball endmill	.006-.008	.004-.006	.006-.008	.004-.006	100 ipm/18k
52-564	1/4" flat endmill (foam only)					100 ipm/18k
52-285/7	1/4" flat endmill (no foam)	.007-.009	.005-.007	.006-.008	.005-.007	
52-280B	1/4" ball endmill	.007-.009	.005-.007	.006-.008	.005-.007	100 ipm/18k
52-330	3/8" flat endmill (no foam)	.008-.010	.006-.008	.007-.009	.006-.008	
52-320B	3/8" ball endmill	.008-.010	.006-.008	.007-.009	.006-.008	100 ipm/18k
52-574	3/8" flat endmill (foam only)					100 ipm/18k
56-360	1/2" flat endmill (no foam)	.008-.010	.007-.009	.007-.009	.007-.009	
56-367	1/2" flat endmill (no foam)	.008-.010	.007-.009	.007-.009	.007-.009	
52-360B	1/2" ball endmill	.009-.011	.007-.009	.008-.010	.007-.009	100 ipm/18k

 DO NOT USE THIS COMBINATION

 56-200 series tool recommended

## PART 2 BIT BASICS

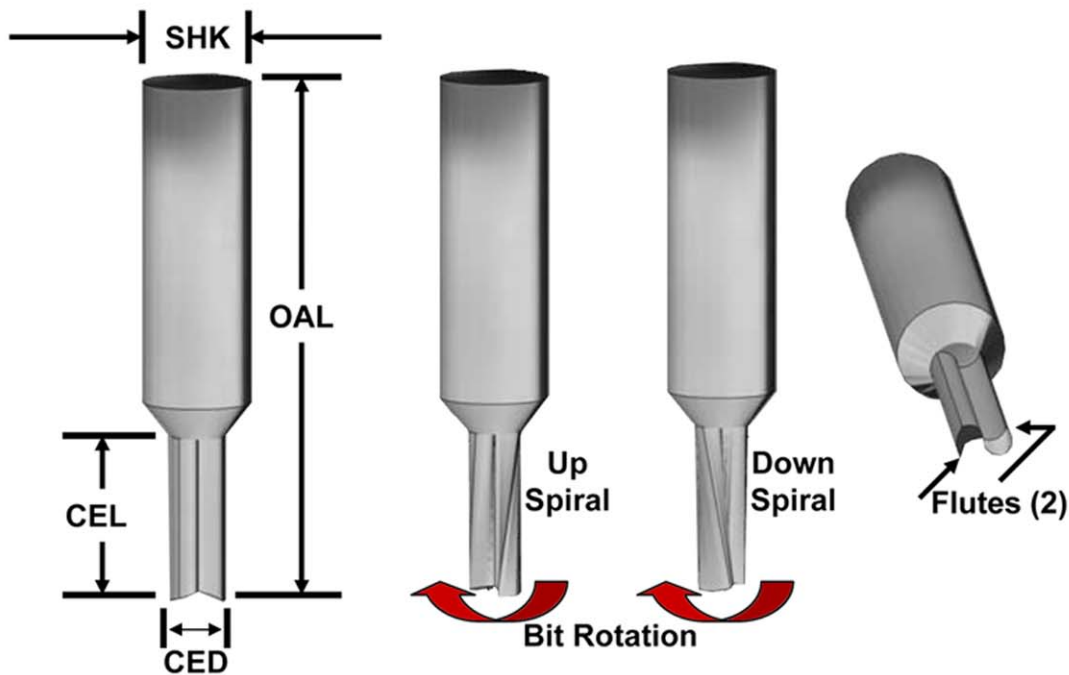

**HSS – High Speed Steel** A tool steel far superior to carbon steel when used for drill bits and cutting tools. A HSS drill bit can drill a hole much faster than a carbon steel bit, hence its name. Quite the innovation in the 1940's! We've moved past this type of tool steel today, HSS bits are only suitable for cutting foams. (some disagreement here)

**SC – Generally just called Solid Carbide.** A very tough wear resistant steel. Many forms of Carbide exist (silicon carbide, tungsten carbide, Beryllium carbide, etc.) as do forms with different grain size. Solid carbide router bits can vary from worthless to extreme high quality. Mass marketers can honestly say "solid carbide" and sell you total junk. If it's cheap... there's a reason. Develop a relationship with a supplier you trust! (one note of caution.. SC bits are brittle, I've had them shatter when dropped!)

**Carbide Tipped** – Carbide is expensive... larger diameter bits are available with chunks of carbide brazed (welded) to a steel body. This reduces the total amount of carbide used to make the bit and hopefully the price. Every thing above applies here. Generally, bits with .1" or more carbide thickness is considered a sharpen-able bit.

**Note:** a sharpened bit may no longer be its full design diameter, and will need to be compensated for in the CNC software.

**OTHER** – There are many other exotic router bit materials available... Diamond, Diamond like, poly crystalline, and more. These bit materials tend to be used in specialty, high volume, and niche markets. I hope your business grows to the point where you need to research and use these types of bits!

# PART 2 BIT BASICS

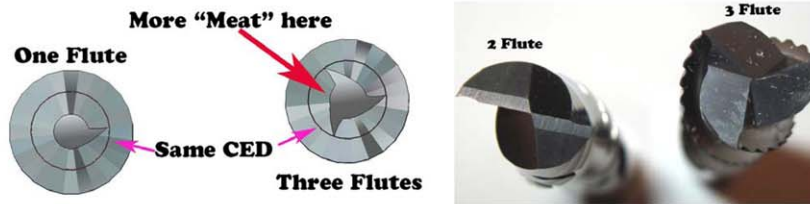
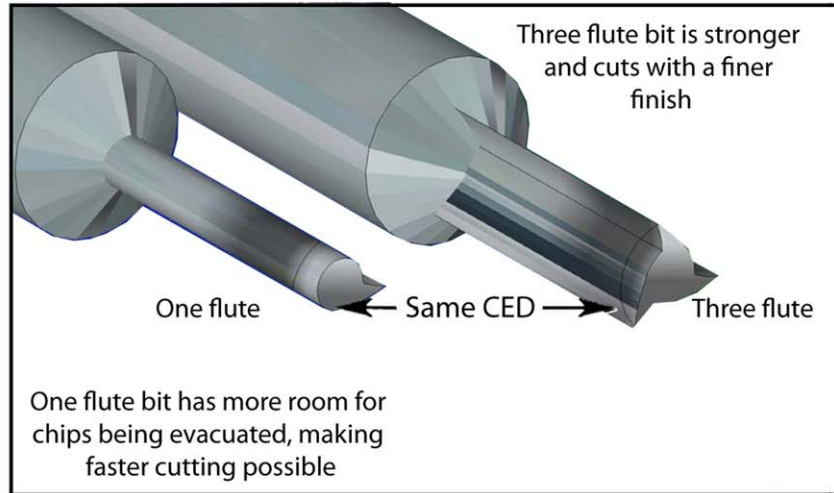

Not all bits are created equal or for the same purpose or to cut the same materials. Bit geometry can affect its usefulness for a specific purpose. Lets try to sort through some major differences!

**Flutes** –The Number of flutes refers to the number of cutting edges that are cut into the body of the tool. More flutes increases the strength of the tool, but reduces space for chip flow. You can cut fast with a single flute tool, but the finish of the three flute will be smoother. CNC router bits are commonly available in 1, 2 and less commonly 3 flute configurations. (there are exceptions to every statement)

## Shear

The flutes of a bit can be shaped (or ground) to obtain different advantages when cutting different materials.

**Straight** – Straight bits have their cutting edges parallel to the body or shank of the bit. The only advantage I can come up with is cost. It's cheaper to manufacture bits this way. Exotic, expensive CNC grinding equipment is not required to make this old fashioned standby bit. I'm not aware of any brazed or carbide tipped bits that are not straight geometry bits, including shaped bits we'll talk about later.

## PART 2 BIT BASICS

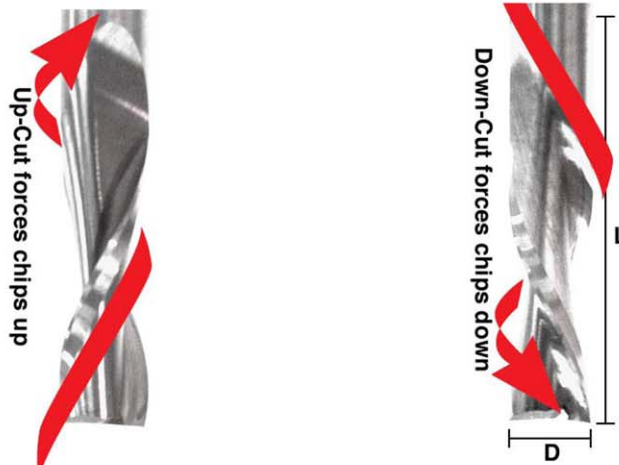

**Spiral** – The flutes of this bit are ground (cut) in a helix around the shank or body of the bit. They cut with a shearing action that is smoother and with less vibration than a straight bit. A straight bit has the entire cutting edge of a flute in contact with the material being cut at the same instance in time, while a spiral flute edge has a very small contact area continuously moving or shearing during the rotation of the bit. A spiral bit always has a part of one or more flutes in contact with the material being cut, while a straight bit is only in contact while that particular flute passes by. There are three major types of spiral bits, each has their advantages and disadvantages for particular uses.

**Up Cut** – The flutes on this type of spiral bit shear from the bottom up, pulling chips up, This clearing or cleaning action allows for deep cuts with less stress on the tool. The major disadvantage of this geometry is that the up-cut action can lift the part up and off whatever is holding the part on the router table. Also, up cutting action can splinter the top face of veneered or other susceptible materials

**Down Cut** – The “down-cut” spiral bit flutes are designed to cut from the top surface down, leaving a smooth edge at the surface. It pushes down on the material being cut, and helps hold the material in place on the table surface. Some operators like this bit as it packs the sawdust in the groove being cut, this helps hold parts in position and helps maintain vacuum when that type of hold down system is used. Disadvantages are the packed sawdust is not removed by the dust collector and must be scraped or brushed off manually. Also this bit is not appropriate for thermoplastics as the “packing” of the dust re-welds the parts together. When making “through cuts” the down cutting force can splinter the bottom face of veneered or other susceptible materials

**Compression** – The third type of spiral bit is a hybrid design of the up and down cut bit. This bit has a up cut portion on the lower part of the bit and down cut on the remainder of its CEL. Material being cut is augured downward from the top of the material and upward from the bottom. This compression of cutting forces results in a clean, splinter free top and bottom face. A special type of compression bit is the **Mortise** compression. This style has a much shorter up-cut section than the standard compression bit and is used for grooves and dados as shallow as ¼" while still having a splinter free top surface.



## PART 2 BIT BASICS

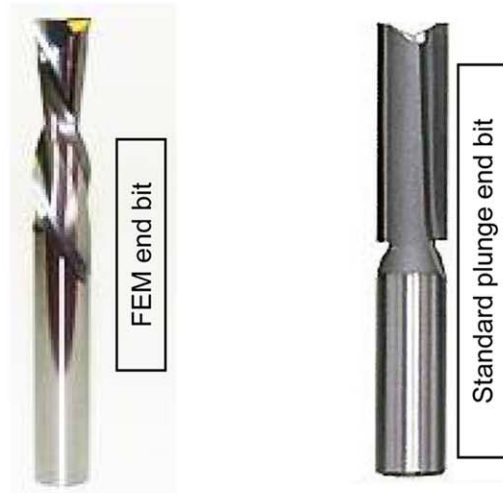

**Standard End** – bits will plunge cut nicely, these bits can be identified by the swallow tail style profile of the end of the bit. This bit is the right choice when cutting profiles. The disadvantage of this style bit is it leaves marks or swirls when pocket cutting.

**FEM** – (flat end mill) this style of end geometry is designed to cut a smooth bottom surface when pocketing. The disadvantage of this style is it need to be ramped into its cut. Forgetting to do this will result in a burned bit. The end profile of this bit is flat.

Some router bits are designed for plunge cutting and some are not.



**Ball** – Ball bits are used to give a radius to the inside corners of pocket cuts. When used for 3D projects with low percentage stepovers, the radii help blend each path together, resulting in less finish work. A ball nose bit is a poor choice for profile cuts as the bit will have to go past the bottom of the material the radius of the bit into the spoilboard to get a clean profile.

# PART 2 BIT BASICS

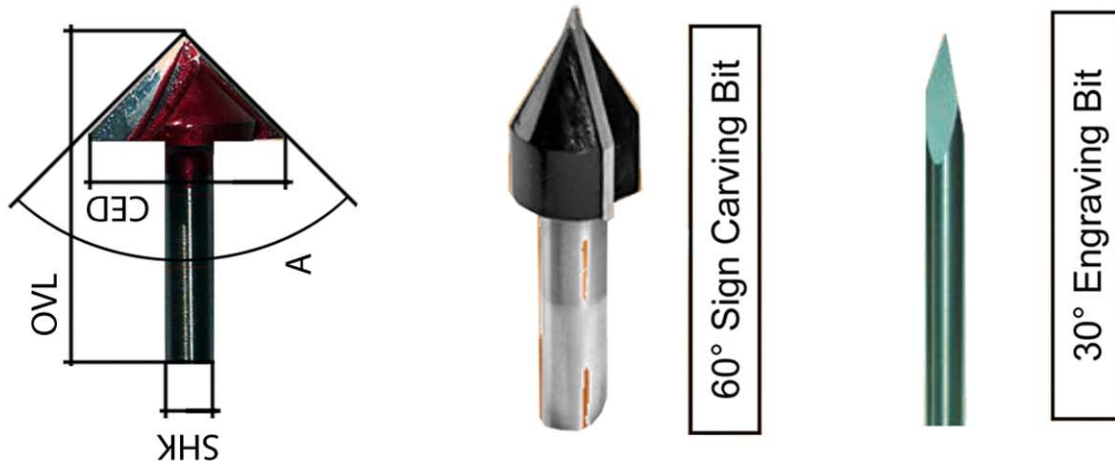

This category of bits will include any bit that is not intended to cut a straight profile. The most common for CNC users will be the V-bits, next the plunge shape cutters for faux raised panel doors followed by any number of specialty bits (like toy train track bits). Somewhere in this discussion it needs to be said... **NEVER use a ball bearing or piloted bit in a CNC router.** The computer/CNC equipment is "piloting" the bit, using these will result in interference between the bit and the equipment and yield lost steps, damaged parts or worse!

**V-bits** – Come in many flavors, and are typically used for signs and V-carving (a topic worthy of its own write-up) some things that affect how they are used are:

**Angle:** measured as the included angle, v-bits are commonly available in 30°, 45°, 60°, 90°, and 120°. the tip of a V-bit can come to a true point, a small radius or a flat.

**Diameter:** measured perpendicular to the shank, this is the width of a full depth cut at the surface of the material.

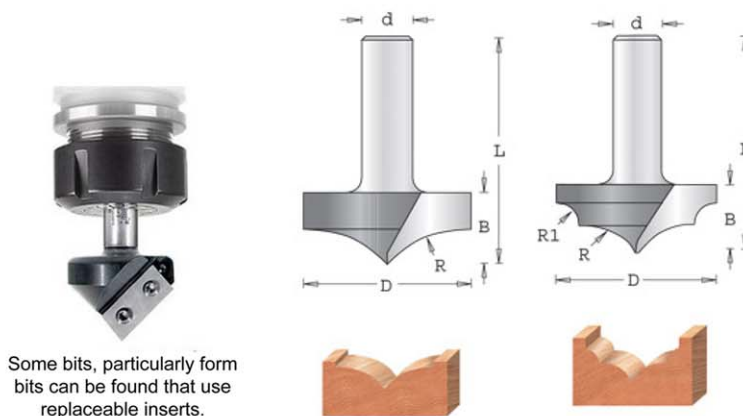

Some bits, particularly form bits can be found that use replaceable inserts.

**Form Bits** – This is a wide open category... the only restriction I'm aware of is it must be able to plunge. Some of these bits remind you of the ogee and radius combo bits used with a bearing pilot... only there's a flat or radius or point where you might expect a pilot. often these bits are used for decorative grooves and in combinations to create faux raised panel doors in MDF.

# PART 3 V CARVE PRO CAM SOFTWARE INTERFACE AND MACHINING OPERATIONS

In order for the CNC machine to work it needs coded instructions to tell it what to do. While a design is made in CAD (Computer Aided Drafting) software, "tool paths" and the resulting code is generated in CAM (Computer Aided Machining) software. There are many software packages available but our CNC Router Lab uses a software called **V Carve Pro**. This software uses a 2D or 3D design and allows the user to create various tool paths which can be exported as code files for the CNC Machine. Below are some of the interface screens for the V Carve Pro. The software is currently installed on a computer in the Digital Arts Lab in the Visual Arts Building. Please visit the Laser Cutting Lab during our open hours to use V Carve Pro.

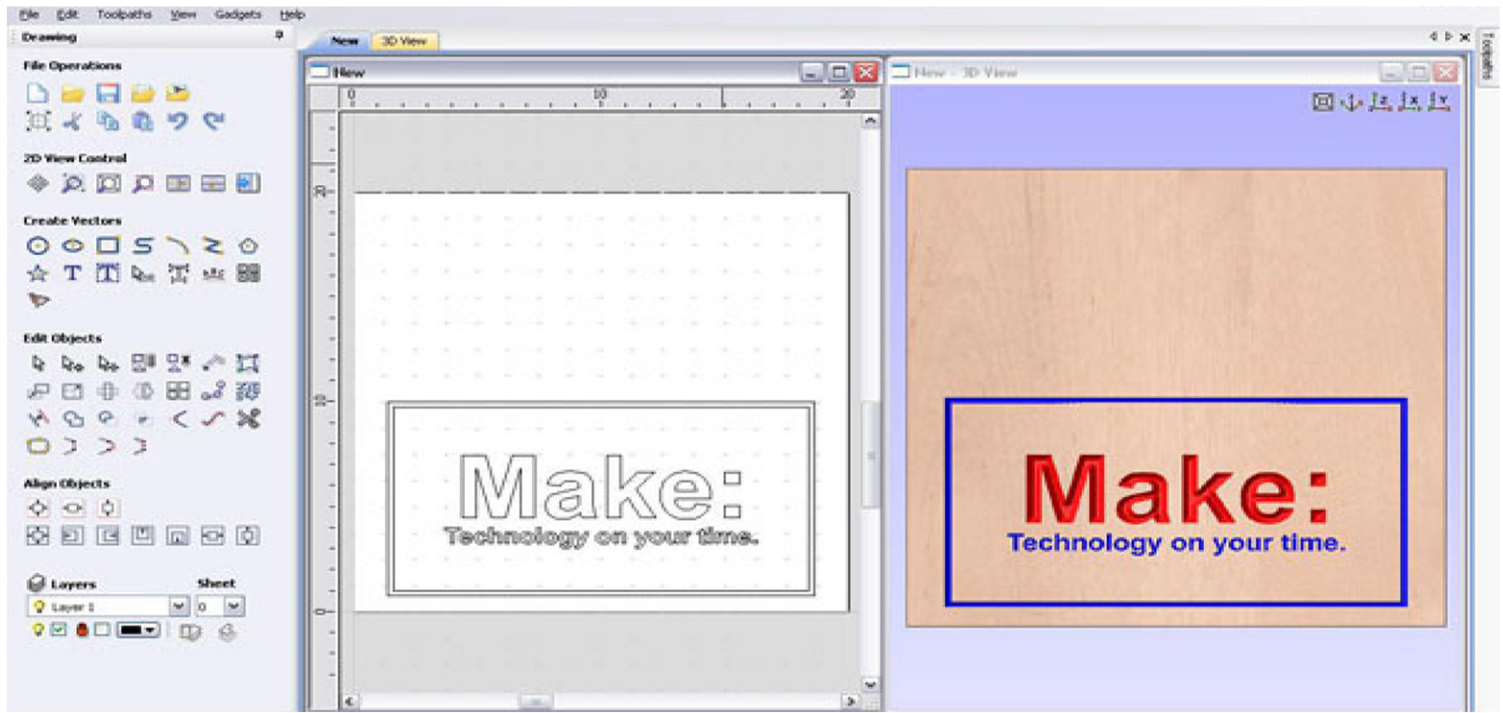

V Carve Pro can create 2D tool paths to cut out material and can also create 3D tool paths to sculpt complex 3D objects. The CNC Certification Tutorial is essentially a tutorial on V Carve Pro so CNC users learn the software and have the ability to competently and safely create their own CAM files which will be checked and run by the CNC operator in the Lab.

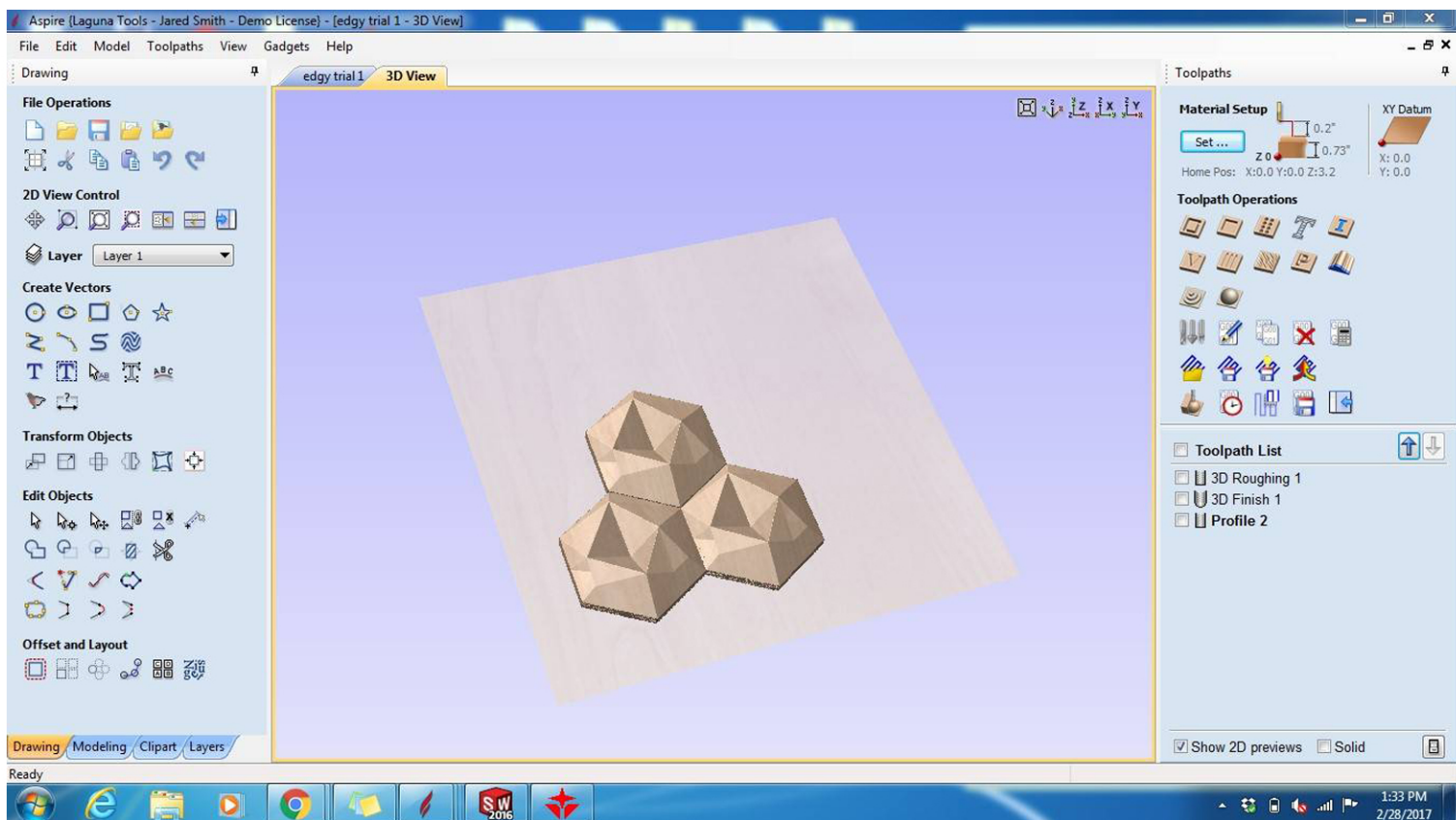

# **PART 4** MATERIALS AND APPLICATIONS

## **CNC MATERIAL OPTIONS AND APPLICATIONS:**

### **Solid Wood:**

Cottonwood, Pine, Redwood, Ash, Oak, Beech, Birch, Cherry, Mahogany, Hard maple, Poplar, Teak, Walnut, Hickory, Purple Heart, Leopardwood, Tigerwood, Cocobolo, Bloodwood, Alder, Aspen, Basswood, Beech, Yellow Birch, Cypress, Red Elm, Gum, Hackberry, Pecan, Pacific Coast maple, Red Oak, Sassafras, Sycamore, Black Walnut, White Oak, Willow, African Padauk, Bolivian Rosewood, Hondura Mahogany, Wenge, Spanish Cedar.

### **Soft Wood:**

Pine, Soft Maple, Fir, Spruce, Hemlock, Cedar, Redwood.

### **Composite Wood:**

OSB, MDF, LDF, Melamine, Particle Board, Plywood, Masonite.

### **Plastic:**

ABS, Polycarbonate, Polyethylene, PVC, Polypropylene, Polystyrene, Cast and Extruded Acrylic, HDPE, UHMW, Marine PVC, Lexan, Phenolic, Sintra, Nylon, Lucite, Solid Surface Materials, Luan, PET, Acetate, VHMW, Mica.

### **Foam:**

EVA, Precision Board, Sign Foam, Polystyrene, Polyethylene, Styramfoam, Polyurethane, Foam Rubber, Silicone Rubber, Urethane.

### **Other:**

Machinable Wax, Ren Board, Vinyl Coated Panels, Butter Board, Magnetic Rubber Mats, Composites, Leather, Mother-of-Pearl, Wood Veneers, G10, Delrin, Mat Board, Rubber.

## **APPLICATIONS**

Furniture	Countertop Production
Prosthetic Manufacturing	Solid Surface Production
Prototyping	Radius Mouldings
Aerospace	Foam Packaging
Mannequin Production	Packaging
Musical Instrument Manufacturers	Extrusions Cutting Boards
Boat Building	Fabricators
Woodworking	Safety Enclosures
Custom Millwork	Engraving
Cabinetry	Conveyor Manufacturers
Fixtures	Pool Cues
Channel Letters	Knife Template Manufacturing
Joinery	Fan Blade Manufacturers
Sign Making	Gun Stock / Pistol Grip Manufacturers
Jewelry Manufacturing	Artistic Carvings
CAD/CAM Instructional	Puzzles
Model Making	MDF Doors

## **TERMINOLOGY AND ABBREVIATIONS**

### **SOFTWARE TERMINOLOGY**

**MOP Set-** Short for Machine Operations Set. This is the set of code (NC) files created in CAM software and specifically V Carve Pro. It is a set of coded instructions for describing geometry, cut patterns, dimensions, bits, profiles, speeds, etc. It is the set of instructions that is exported as a code file for Maker Corp operators to check and run.

**CAM File-** A file created by CAM software, often Z Carve Pro, that describes all cutting parameters.

**NC File (G code)-** A file exported from CAM software specifically coded to communicate with the Laguna Swift CNC Machine.

### **CUTTING TERMINOLOGY:**

**Step Over-** The dimension between horizontal cutting passes. This dimension can be smaller to produce smoother results or conversely larger to create bit based texture. As a general rule of thumb, the step over should be half the dimension of the bit being used.

**Step Down-** The dimension between vertical cutting passes. This dimension should generally be equal to the bit width.

**Feeds and Speeds-** feeds are the rates of cut speeds and are measured in inches per minute and speeds refer to the rate of spindle rotation speed and are measured in revolutions per minute.

**Chip Load-** This is the thickness of a chip which is formed during the machining of material. Chipload is important because the proper size chip will carry away heat, promoting long tool life. When the chip is too small, heat is transferred to the cutting tool causing premature bit failure. Too high of a chipload will cause poor edge finish, and transfer cutting load or thrust to the part, possibly causing it to move. A bit in good condition and running at recommended loads will be at room temperature when a cut is finished.

**BBT-** Bit based textures. An abbreviation for cut patterns that rely on bit depth and step over to create character.

**PROFILING-** Using lines to essentially cut out pieces of from a material, similar to a laser cutter.

**RPM-** An abbreviation for revolutions per minute, generally used to describe CNC spindle rotation speed.

**IPM-** An abbreviation for inches per minute, generally used to describe cut rates.

**Plunge Rate and Angle:** The speed and angle of the entry and exit cut.

### **CNC MACHINE TERMINOLOGY**

**3 axis milling-** Milling operations that engage the X, Y and Z axis simultaneously (often used to create relief or textured surfaces).

**2.5 axis milling-** Milling operations that engage the X and Y axis simultaneously and the Z axis only independently (often used to create profiled or cut pieces).

**Collet-** The part of the CNC machine that holds the bit. It is a sleeve attached to the spindle with a collet nut.

**Collet Nut-** The nut that is affixed to the spindle and holds the collet.

**Arbor-** The part of the CNC machine that allows the spindle to move in the X, Y and Z axis. The arbor is the framework above the table that holds the spindle.

**Spindle-** The part of the CNC machine attached to the arbor that spins. This is the piece to which you attach bits with the collet and collet nut.

**Spoil Board-** The MDF board under the piece to be milled. This acts as a buffer between the bit and the table insuring a cut that goes through the material won't damage the table.

## **PURCHASING BITS AND MATERIALS**

### **ORDERING BITS**

**(ask for advisement - not all bits will work)**

<https://www.endmilldiscount.com/>

<http://www.onsrud.com/>

<http://www.razorsharpgrinding.com>

<http://www.bamcarbide.com/>

<http://www.woodworkerswholesale.com/>

### **PURCHASING BITS LOCALLY**

**(ask for advisement - not all bits will work)**

Marty's True Value Hardware  
1751 Van Vranken Ave, Schenectady NY 12308  
(518) 372-2311  
Hours: M-F 8am-6pm  
Sat 9am-5pm  
Sun 10am-2pm

Lowe's Home Improvement  
93 Fremans Bridge Road, Glenville NY 12302  
(518) 952-8789  
Hours: M-Sat 6am-10pm  
Sun 8am-8pm

### **PURCHASING SHEET MATERIALS (NOT VETTED)**

Lowe's Home Improvement  
Home Depot  
84 Lumber  
Cushman Lumber  
Bellevue builders Supply  
Long Lumber and Supply  
Curtis Lumber  
L J Valente Lumber  
Hankle Lumber  
Nordic Engineered Wood  
ABC Supply Company  
Little Falls Lumber

## RESOURCES AND INFORMATION

### CNC RESOURCES:

<http://www.talkshopbot.com/forum/>

<http://www.cnczone.com/>

<http://www.machinetoolhelp.com/>

<http://www.machinetoolhelp.com/Links/CNC-Machine-tool-forums.html>

<http://www.practicalmachinist.com/>

<http://www.cncci.com/index.html>

<http://www.techedcnc.com/>

<http://support.technocnc.com/>

### CAM SOFTWARE RESOURCES:

#### V CARVE PRO VIDEOS

<https://www.vetric.com/support/tutorials/vcarve-pro?playlist=TutorialCategories&category=GettingStarted>